

# EVALUATION OF 2D SHAPE LIKENESS FOR SURFACE RECONSTRUCTION

Prof. Dr. Ruiz, Oscar Eduardo  
Prof. Dr. Cadavid, Carlos Alberto, Student Assistant Granados, Miguel  
CAD / CAM / CG Laboratory  
EAFIT University  
Cra. 49 No 7-sur-50, Medellín, COLOMBIA  
E-mail: [orui@eafit.edu.co](mailto:orui@eafit.edu.co) ;Tfno.: +57(4)266-0500 ext 521 ;Fax. +57(4)266-4284;  
Thematic Group: Geometry and Computational Geometry

## 1. Summary

Surface or shape reconstruction from 3D digitizations performed in planar samplings are frequent in product design, reverse engineering, rapid prototyping, medical and artistic applications, etc. The planar slicing of the object offers an opportunity to recover part of the neighborhood information essential to reconstruct the topological 2-manifold embedded in  $\mathbb{R}^3$  that approximates the object surface. Next stages of the algorithms find formidable obstacles that are classified in this investigation by the following taxonomy: (i) Although real objects have manifold boundaries, in objects with thin sections or walls, the manifold property remains in the data sample only at the price of very small sampling intervals and large data sets. For relaxed sampling rates non-manifold situations are likely. (ii) The position of the planar slices may produce an associated level function which is non – Morse. This for example allows the set of critical points of the associated level function to contain one or even two dimensional pieces. The fact that the Hessian matrix at critical points is non-singular is the Morse condition (as a consequence, critical points are isolated), and allows for the algorithms presented here. (iii) For Morse condition, the slicing interval may be such that several critical points occur between immediate slices (non- simple condition). This article presents the degenerate cases arising from points (i)-(iii) and discusses a shape reconstruction algorithm for digitizations holding the Morse – simple condition. It presents the results of applying the prescribed algorithms to data sets, and discusses future actions that enlarge the mentioned scope.

### Glossary

$C^0, C^1, C^2$	type of continuity (contact, tangent, curvature, respectively)
$M$	2-manifold in $\mathbb{R}^3$ ( $C^\infty$ or $C^0$ or $PL$ , with / without boundary)
$PL$	Piecewise Linear
face	domain on 2-manifold $M$ in $\mathbb{R}^3$ whose boundary is a disjoint union of simple closed paths
facet	triangle in $\mathbb{R}^3$
$f_i$	facet
$\delta$	sample distance between two points on $M$
shell	synonymous with “connected PL 2-manifold with boundary”, and with “partial mesh”
$S$	digitization point set in $\mathbb{R}^3$
$\partial B$	boundary of a set $B$
$L_j$	j-th level of the digitization
$M_{j,j+1}$	manifold with boundary corresponding to the portion between $L_j$ and $L_{j+1}$

## 2. Introduction And Literature Review

Surface reconstruction has turned out to be an essential need in areas as diverse as medical imaging and artistic applications, product design, reverse engineering and rapid prototyping, among others. Traditional surface reconstruction methods do not perform well in two senses: 1) they cannot handle the highly complex cases

found in nature (e.g. human organs or microscopic images of tissue) and 2) they do not put the surface data in a form which is compact and fit for simulation, visualization or navigation. The main reason for these shortcomings is that these methods were conceived disregarding the relevant body of knowledge of topology and geometry developed in mathematics over the last century.

The form of the Surface Reconstruction Problem (SRP) that is addressed in this paper is the following. Suppose that the cross sections of a solid in euclidean 3-dimensional space cut by a set of parallel, evenly spaced planes is given. It is understood that the distance between the planes is such that enough detail of the solid's bounding surface is captured. The problem is to give a computer algorithm that constructs an approximation of the original surface out of this cross section sampling.

To put the problem in a mathematical framework it is necessary to start making some assumptions about the nature of both, the solid and the set of planes defining the cross sections: (i) It is assumed that the solid is a closed and bounded subset of  $R^3$ , whose boundary is a  $C^2$  2-manifold. This implies that (ii) the height function associated to the cross sections is  $C^2$ . As discussed below, these assumptions render an intricate problem when relating cross sections from one level to the next. In spite of non-Morse functions being found in practice, this investigation seeks to understand and attack the Morse case first. Moreover, according to considerations exposed ahead, (iii) the height function is assumed to be Morse-simple. The solution to the SRP is a  $C^0$  2-manifold.

The main topics for surface reconstruction from planar samples are (i) physical sampling and its characteristics (interested audience is invited to read [Varady.97] for deeper insight on reverse engineering), and (ii) mathematical treatment of the data set to obtain a  $C^0$  topologically correct 2-manifold. Issues such as smoothing (achievement of  $C^2$  2-manifold) are not in the scope of this paper.

## 2.1. Data Acquisition

Acquisition may be by contact or remotely. Contact measurement is based on the position of the kinematic joints holding a probe that touches the object. In most metrology centers (Coord. Measurement Systems - CMS) planar sampling trajectories have 3 degrees of freedom (X-Y-Z table), and therefore recondite features are not reachable. When more degrees of freedom are present (with articulated arms), the probe is able to reach creases and holes, at the penalty of manual measurement. Still, approximate planar samples can be obtained pre-processing ([Ruiz et al.97, Ruiz .2000a]) if other characteristics of the digitization like density, homogeneity, etc, are sufficient.

Range imaging records a depth field in grid patterns corresponding to pixel arrays. Each pixel has associated the coordinates (x,y,z) of the surface point hit by the ray passing through the pixel, as well as the vector describing the ray. The grid data so obtained contains implicit neighborhood information that facilitates topology reconstruction.

## 2.2. Mathematical and Algorithmic Treatment

### 2.2.1. Topology Recovery.

In the surveyed literature Alpha Shapes ([Edelsbrunner.94]) and Marching Cubes ([Lorensen et al.87]) are used as engines for recovering topology information ([Grimm et al.95,Guo.97]) from completely unorganized points. In this article, since a previous classification of  $S$  into planar subsets is possible, an alternative scheme will be followed. For *representation* of the result, B-Rep models ([Mantyla.88]) do not directly serve surface reconstruction since they are watertight closed. Some authors [Varady.97, Neugebauer.97] report the difficulty in completing or inferring lost or hidden regions of the surface. Therefore, an extended B-Rep structure was devised [Ruiz et al.2000b] to record absence of surface and existence of borders on some parts of the recognized surface or partial shell (possibly with holes). Regarding the carrier geometries of the shells, this investigation uses very simple geometries such as 3 and 4 - vertex facets. The last ones are of course non-flat in general, but are easily subdivided into triangles. These primitives have been found sufficient to support a correct topology.

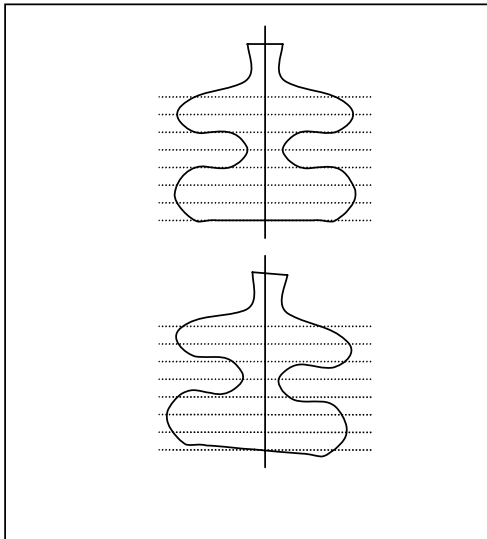

Fig. 1.- Non-Morse (above) vs Morse (below) digitizations.

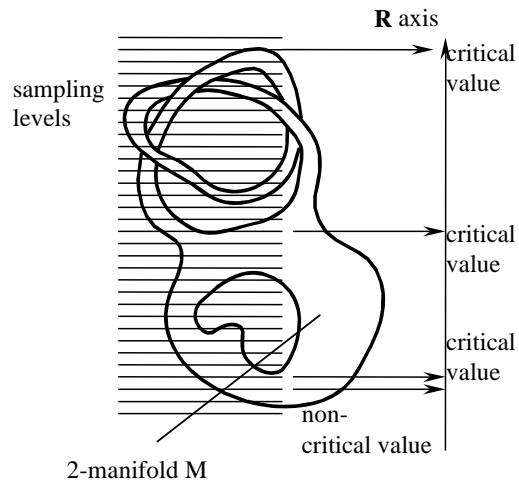

Fig. 2.- Relation between a physical planar sampling process and the Morse function.

In efforts for conciliation of meshes from range images Turk & Levoy [Turk et al.94] use a user provided – alignment to snap an image into another by finding a rigid transformation that, applied to one image minimizes the distance with the other. In [Curless et al.96], Curless & Levoy demonstrate however that [Turk et al.94] fails for cases of high curvature objects. Both approaches intend to build a closed shell, but while [Turk et al.94] erodes overlapping portions of the shells, [Curless et al.96] creates the shells from implicit surface in  $R^3$  ( $f(p) = 0$ ), defined by a statistical reliability associated to portions of the pictures.

### 2.2.2. Surface Smoothing.

Once a topologically correct shell is attained, applications may require a level of continuity (typically  $C1$  or  $C2$ ) on the surface built. Publications [Grimm et al.95,Guo.97] start with a topologically correct  $C0$  shell, and cover it with vertex, edge and face charts in order to obtain a complete mapping between the  $C0$  shell and a manifold  $M$ . This mapping enables the definition of a chart-depending parameterization that produces a  $C2$  continuous surface by using generalized B-spline surfaces.

### 2.2.3. Morse Functions and Planar Digitizations.

Morse theory has been described as “the single-most important contribution of an american mathematician” by Stephen Smale. The reason for this claim is the vast number of important applications this theory has found. [Morse.34] derives some inequalities which express relations between information about the critical set of a special type of smooth function on a smooth manifold and homological information about the manifold. This led to a study of the topological change between infraset of such smooth functions. It is realized that the changes are given by “handle” additions [Fomenko et al.97]. *Handles* are standard simple topological pieces that can be attached to the boundary of a manifold, changing its topology. One should remark that Morse theory only takes care of a particular aspect of topological change between levels. In this paper we go one step further in that we also need to take into account the position in space and shape of the added handles.

In [Shinagawa et al. 1991] a method to encode the topology and position of a surface in space by recording the topological evolution of its infraset is given. The authors also use the Reeb graph [Reeb.46] for this recording. They give a method to construct a surface out of a given code.

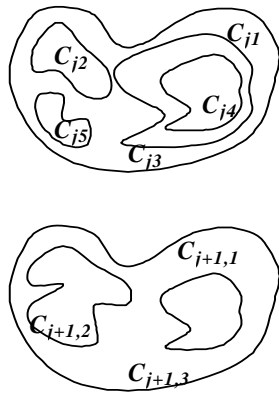

Fig. 3 – Cross sections of levels  $j$  and  $j+1$ .

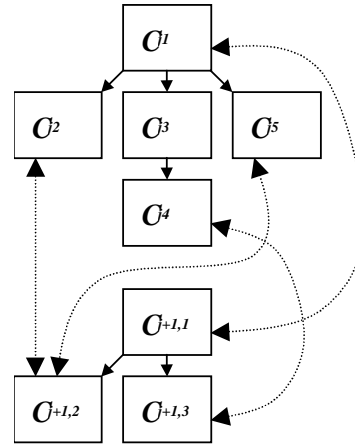

Fig. 4 – Graph mapping between levels  $j$  and  $j+1$ .

In this paper one starts out with a cross section sampling with height function being Morse-simple. Then the computer algorithm assesses the topological changes between consecutive levels (based on Morse theory, combinatorics of contour nesting and geometric similarity) and then proceeds to use this information to construct a surface which is an approximation of the original. Our idea is to first study the problem from the point of view of differential topology, more exactly, Morse theory. This with the intention of obtaining *a priori* information and derive a taxonomy that would help in cutting down possibilities in level linking. In this paper we study the Morse-simple case. Other approaches to SRP, like in [Barequet et al.96] [Bajaj et al.], concentrate on directly using the geometry for linking levels, without any previous inventory of “all that can happen”.

In this article, section 2 presents taxonomy of the problem. Section 3 methodology developed. Section 4 displays the results of application of the proposed methodology and section 5 concludes the paper.

### 3. Taxonomy of Problem

In this section we make a mathematical taxonomy of the surface reconstruction problem.

One starts with a closed and bounded subset  $B$  of  $R^3$ , and the intersections between its boundary (denoted by  $\partial B$ , and defined by  $B$ -interior( $B$ )) and a number of evenly spaced parallel planes. Fix a straight line perpendicular to these planes, and parameterize it with  $R$  in a linear fashion. This defines a function  $f: \partial B \rightarrow R$  given by orthogonal projection on this line.

We first consider the nature of  $\partial B$ . The boundary of solids found in the real world is always at least a  $C^0$  2-manifold. However, we remark that due to limitations in digitization rates, the boundary of some solid objects should be considered non-manifolds. For instance, leaves of plants are too thin compared with other parts, such as stems. So in practice it is better to consider their boundaries as non-manifolds. They could be modeled by simplicial complexes.

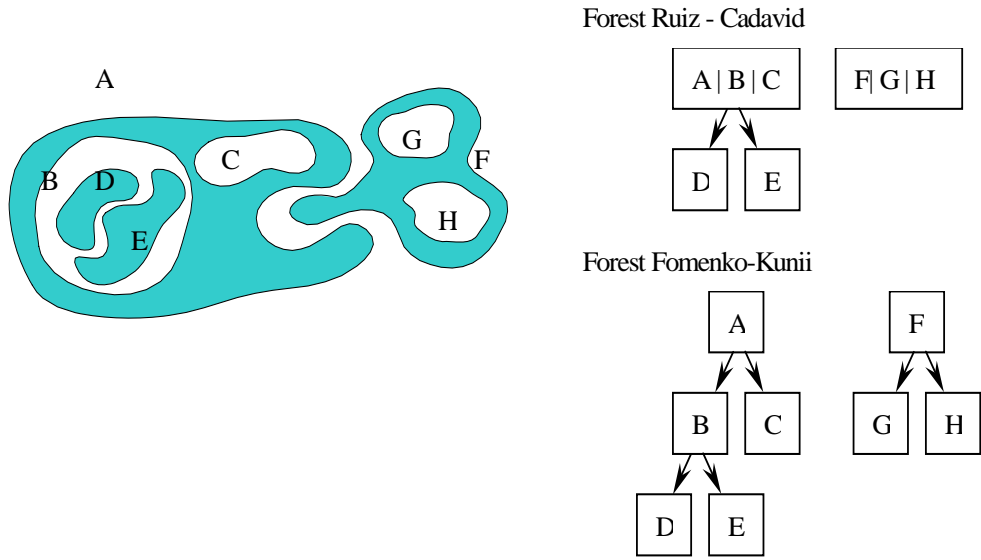

Fig. 5 - Forest structures to represent cross cuts of 2-mainfold

The assumption that  $\mathcal{B}$  is a  $C0$  2-manifold is too raw.  $C0$  manifolds are generally intractable since one cannot do calculus on them. This is why one assumes that  $\mathcal{B}$  is a  $C2$  2-manifold. Note that some common surfaces are  $C0$  manifolds (e.g. a cube) but they can be approximated by  $C2$  manifolds (e.g. rounded-edged cube).

Now we focus on the nature of the height function  $f: \mathcal{B} \rightarrow \mathbf{R}$ . Note that  $f$  is automatically  $C2$ . There is a condition on  $f$  (the so called Morse condition) of great importance in differential topology.  $f$  is Morse if the Hessian matrix at each critical point of  $f$  is non-singular. This condition turns out to be relevant to SRP because it is relatively easy to understand the topological change from one infraset of  $f$  to the next. When  $f$  is non-Morse the topological evolution between infraset is complicated and there would be too many topologically correct ways to link two consecutive levels.

Even the general Morse case is difficult to handle. Morse functions are divided into Morse-simple and Morse-nonsimple (or Morse-complicated). A Morse function is simple if each critical level contains exactly one critical point. When the function  $f: \mathcal{B} \rightarrow \mathbf{R}$  is Morse-nonsimple, one still has too many topologically consistent ways to link levels. And many of these choices lead to a connected surface, therefore, connectedness is not a restrictive enough criteria either.

#### 4. Methodology

This section discusses an algorithm to establish a mapping between two consecutive planar samples of  $C2$  2-manifolds for Morse – simple conditions.

##### 4.1. Representation for Planar Slices of a $C2$ 2-Manifold

A  $C2$  2-manifold  $M$  embedded in  $R3$  presents a Morse function that happens to be a mathematical abstraction of the sampling process. Non-Morse digitizations (Figure 1) may present continuous sets of critical points (maxima, minima and inflection points). Morse digitizations have isolated critical values. Figure 2 displays the relation between the Morse function and the physical sampling. If the family of sampling planes has normal vector  $\mathbf{n}$ , without loss of generality let us assume that  $\mathbf{n}$  is coincident with the  $Z$  axis and therefore the associated Morse function  $fn: M \rightarrow \mathbf{R}$  is  $fn(x,y,z)=z$ , for  $(x,y,z) \in M$ .

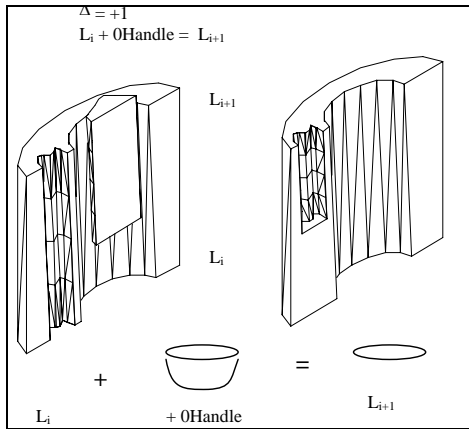

(a) Birth-of-Minima transition

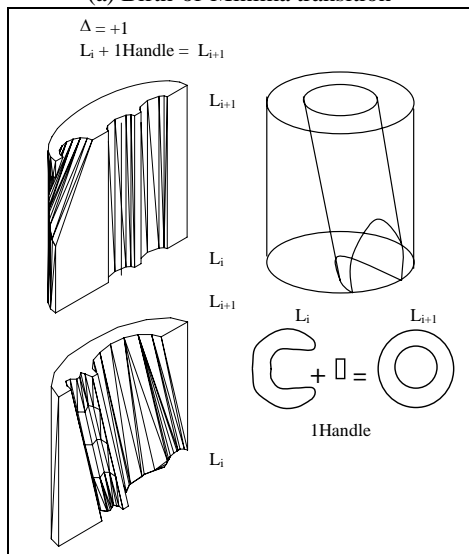

(b) Croissant-Donut transition

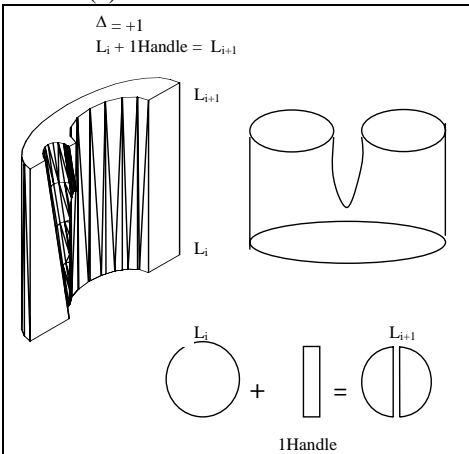

(c) Pant transition

Fig. 6 - Transitions resulting from surplus contours of 1 ( $\Delta = +1$ ) between levels  $L_i$ , and  $L_{i+1}$ .

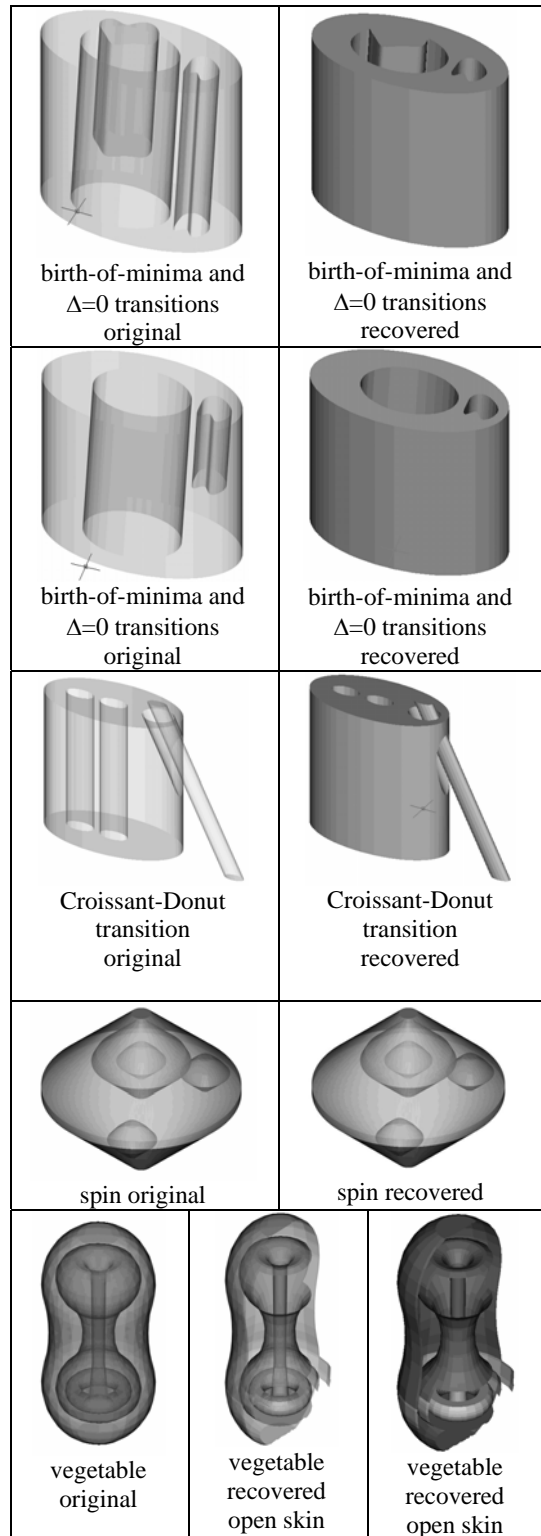

Fig. 7 - Preliminary results

For closed 2-manifold surfaces (as opposed to manifold with boundaries) each planar slice of the manifold  $M$  can be represented by forests (sets of tree data structures). Figure 3 displays the cross section on planes  $j$  and  $j+1$ ,

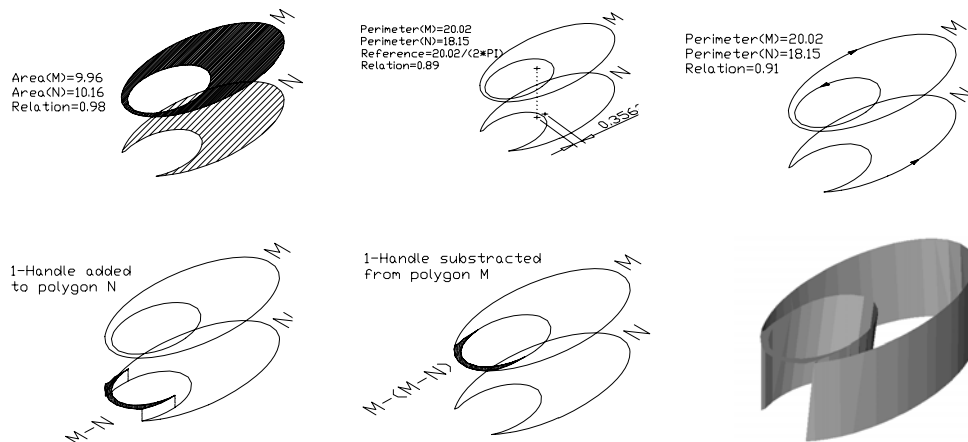

Fig. 8 - Algorithm to infer relations between set of contours in levels  $L_j$  and  $L_{j+1}$ .

while Figure 4 displays the correspondences that intuitively exist between contours of level  $j$  with those of level  $j+1$ . For another example of a cross cut, Figure 5 shows the forest representing it. The data structure proposed here differs with the proposed by [Fomenko et al.97] since our hierarchy explicitly records the relation between nodes A, B, C as B, C representing absence of material or holes within A. This distinction is remarked here since non-Morse digitizations do not permit to make the assumption that if A is an external contour and B is a child contour of A, then B represents an internal wall. The proposed data structure explicitly stores the fact that B is the trace of an internal wall, contained within the external one, A. The implication of this assumption will be discussed in sections 3 and 4.

The evolution of the contours cut on the manifold  $M$  by two consecutive parallel planes can be represented by a relation. Let  $F_j$  and  $F_{j+1}$  be the forests (as in Figure 5) that represent the cross sections of the manifold against sampling levels  $L_j$  and  $L_{j+1}$  respectively. Then, the skin  $S_{j,j+1}$  is the relation:

**Definition. Skin.**  $S_{j,j+1} = \{(a,b) \mid a \in F_j, b \in F_{j+1}, \text{ with } a,b \text{ borders of } 2\text{-manifold with boundary } M_{j,j+1}, \text{ with } M_{j,j+1} \subset M \text{ and } M = \cup_j (M_{j,j+1})\}$

This definition establishes that contours  $a$  and  $b$  are part of the skin ( $M$ ) if they are (some of the) borders of the manifold with boundary  $M_{j,j+1}$ , resulting from sectioning  $M$  with planes  $L_j$  and  $L_{j+1}$ . The definition also states that joining the portions  $M_{j,j+1}$ , of the manifold  $M$  contained between levels  $L_j$  and  $L_{j+1}$  for all levels  $j$  recovers the whole  $M$ .

## 4.2. Transitions between Level Forests

The cases considered in this publication concern the case *Morse-simple* in which the difference between number of contours in levels  $L_j$  and  $L_{j+1}$  is  $\Delta=0$  or  $\Delta=\pm 1$ . For all the cases discussed it is clear that  $\Delta$  alone is not enough to define the type of transition to be identified. Therefore, geometric heuristics are used. The analysis of cases follows (see Figure 6):

$\Delta=0$ . The total number of contours would remain.

The following cases are possible:

(i) Simultaneous birth and death of equal number of minima and maxima. In this condition, an equal number of 0-handle and 2-handle would be present. This case is not possible if one assumes the sample meets Shannon [Shanon.49] criteria on sampling of digital systems, and Morse – simple conditions. These ensure that an adequate sampling interval was used, and therefore complex transitions are indeed recorded.

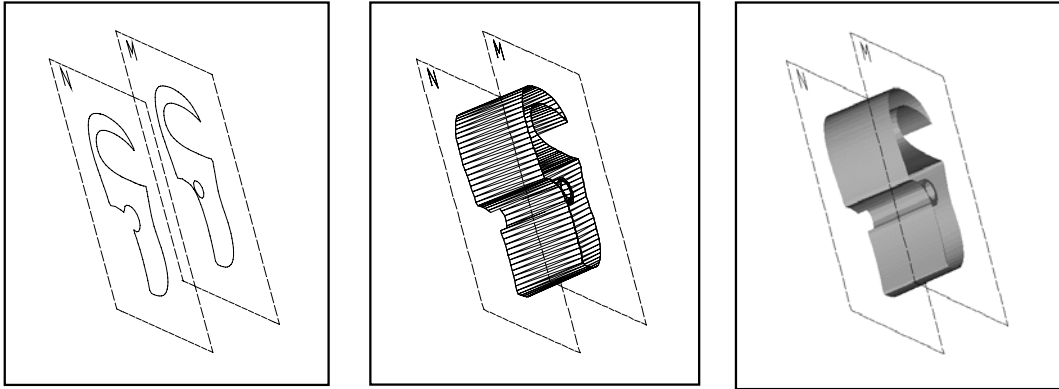

Fig. 9 - Addition of 1-handle. Croissant – Donut transition.

(ii) No births and deaths are present, the contours map one to one from level  $L_j$  to  $L_{j+1}$ , but the geometry of the tubes is intertwined (braid pattern). The total number of contours would remain. This case is again not possible because of Shannon's sampling theorem criteria.

(iii) No births and deaths are present, the contours map one to one from level  $L_j$  to  $L_{j+1}$ . The tubes are ruled surfaces joining the contours to lift. There is an isomorphism between forests  $F_j$  and  $F_{j+1}$ .

$\Delta = \pm 1$ . The number of contours changes by 1.

For Morse-simple digitizations the following cases are possible when  $\Delta = 1$  (if  $\Delta = -1$  they are symmetric):

(i) A new contour appears as a minima is passed. Topologically, a 0-handle is added. If  $\Delta = -1$  an existing contour dies, and a 2-handle is added (Figure 6.a).

(ii) Croissant-Donut Transition. A new contour appears inside one in level  $L_{j+1}$ , and they face a strongly concave one in level  $L_j$  (see Figure 6.b).

(iii) Pant Transition. A new contour appears outside one in level  $L_{j+1}$ . Geometric Heuristics lead to associate them to one in the level  $L_j$ . In the Morse - simple case we only need to consider 1:2 transitions (Figure 6.c).

### 4.3. Geometry – driven Heuristics

The problem to attack is essentially the calculation of a morphism between two graphs (forests)  $F_j$ , and  $F_{j+1}$ , representing cross cuts of the manifold  $M$  at levels  $L_j$ , and  $L_{j+1}$ . In case of a  $\Delta = 0$  transition (no critical points are between the levels  $L_j$ , and  $L_{j+1}$ ), the relation would be a tree isomorphism. In the other transitions,  $\Delta = \pm 1$ , the trees to match are not isomorphic. In any case, the brute approach to match two graphs results in combinatorial complexity. Therefore, taking advantage of geometric likeness is a compulsory improvement in the process.

The heuristics used to infer which sections from  $F_j$  and  $F_{j+1}$ , relate are based on the fact that corresponding contours do not dramatically change geometry from level  $L_j$ , to  $L_{j+1}$ . However, all of them present extreme cases in which they fail. An important factor to comply with to have reliable results in real applications is the quality of the sample.

### 4.4. Calculation of Interlevel Relation

The algorithm to calculate the relation that represents the partial skin or 2-manifold with boundary between two immediate cross sections is suggested by Figs. 6 and 8. In Figure 8 an example is given of parameters that grade



the similarity between contours in two levels. The transition shown has been named here “donut / croissant” for obvious reasons. The following comments about the algorithm are relevant: (a) the algorithm enables  $n:m$  transitions. (b) The similarity test performs perimeter, area, and center-of-gravity comparisons, and, in recent versions, uses boolean algebra between 2D regions. (c) The algorithm renders symmetric results regardless the order to name  $Lj$  or  $Lj+1$ . (d) Boolean algebra allows us the operations  $M-N$ ,  $M-(M-N)$ ,  $M \cap N$ , etc. With these results, a more reliable criteria (than perimeter, center of gravity, etc) for geometric similarity is devised.

## 5. Results

Figure 7 shows the results of the algorithm proposed for different models with diverse topology, corresponding to  $\Delta = \pm 1$  (“birth” / “death” of minima, “pant”, “donut to croissant”, etc.) transition and no transition ( $\Delta = 0$ ). From Figure 7 it can be appreciated that the algorithms apply in natural way in objects found in nature. In the “vegetable” data set the first picture shows a transparent version of the original data, while the next two are transparent and opaque images of the reconstructed surface, with removal of a wall for better understanding. Figure 9 shows yet another example of the  $\Delta = \pm 1$  situation. The algorithm correctly detects and handles it. The handling is realized by literally applying boolean operations with 0-, 1- and 2-handles to the initial contours to obtain the transformed ones.

## 6. Conclusions

The taxonomy surveyed helps to understand the infinite shape varieties found in nature, and gives a basis for an algorithm to solve the Morse-simple cases. In this effort, further work is being conducted to: (a) Provide more robust and yet flexible tests for similarity between 2D shapes. This test is the basis for the interlevel linking algorithm proposed. (b) The assumption, found in Morse-Simple cases by which the boundary contours can be alternatively classified as internal/external wall can be exploited more deeply, both in making additional correctness tests on the topology, and making more robust the similarity test mentioned above. (c) A careful analysis of the results and algorithm reveals that although it was proposed for Morse-simple cases, it handles non-simple ones if the transitions lie in different trees of the forests  $f_1$  and  $f_2$ .

Of course, further work is needed in Non-Morse cases, Non-simple Morse ones, and in learning to handle non-manifold data.

**Acknowledgments.** The authors wish to thank the economic support of the Deutscher Akademischer Austauschdienst (DAAD) for the internship of Assoc. Prof. Dr. Oscar Ruiz University at Fraunhofer IGD's in 1999 and the Colombian Institute for Science and Technology (Colciencias) through grant FALCON-98 and 99. The research assistant Miguel Granados has done the programming of these algorithms, has fully understood the intent of the author and has formulated important contributions.

## 7. References

[Bajaj et al.] Arbitrary Topology Shape Reconstruction from Planar Cross Sections, to appear in Graphical Models & Image Processing.

[Barequet et al.96] Barequet, B. and Sharir, M., Piecewise-linear interpolation between polygonal slices. Comput. Vision Graph. Image Process, vol 63, 1996.

[Curless et al.96] Curless, B., Levoy, M., A volumetric Method for Building Complex Models from Range Images. Proceedings SIGGRAPH-96, 1996, pp 303-312.

[Edelsbrunner.94] Edelsbrunner, H., Three Dimensional Alpha Shapes, ACM Transactions on Graphics, Vol 13, No 1, Jan, 1994, pp 43-72.

- [Fomenko et al.97] Fomenko, A., Kunii, T. Topological Modeling for Visualization, (Tokio, Springer Verlag, 1997).
- [Grimm et al.95] Grimm, C., Hughes, J., Modeling Surfaces of Arbitrary Topology using Manifolds. Proceedings, SIGGRAPH - 95 Annual Conference Series, Los Angeles, August 6-11, 1995, pp. 359-368.
- [Guo.97] Guo, B., Surface Reconstruction: From Points to Splines. Computer Aided Design, Vol 29, No 4, 1997, pp 269-277.
- [Lorenzen et al.87] Lorenzen, W., Cline, H., Marching Cubes: A High Resolution 3D Surface Construction Algorithm, ACM Computer Graphics, Vol. 21, No. 24, July, 1987, pp. 163-169.
- [Mantyla.88] Mantyla, M., An Introduction to Solid Modeling, (Rockville, USA, Computer Science Press. 1988).
- [Morse,1934] Morse, M., The calculus of variations in the large, American Mathematical Society, New York, 1934.
- [Neugebauer.97] Neugebauer P., Reconstruction of Real World Objects via Simultaneous Registration and Robust Combination of Multiple Range Images. International Journal of Shape Modeling, Vol. 3, No. 1&2, 1997, pp 71-90.
- [Reeb.1946] Reeb, B., Sur les points singuliers d'une forme de pfaff complement integrable on d'une fonction numerique. Comptes Rendus, Acad. Sciences Paris 222, 847-849.
- [Ruiz et al.97] Ruiz, O., Posada, J., Computational Geometry in the Preprocessing of Point Clouds for Surface Modeling. In Book Integrated Design and Manufacturing in Mechanical Engineering-98. ISBN 0-7923-6024-9, (Dordrecht, Netherlands, Kluwer Academic Publishers, 1999).
- [Ruiz.2000a] Ruiz, O., DigitLAB, an Environment and Language for Manipulation of 3D Digitizations. Proceedings of the Joint Conference : IDMMME'2000 & CSME FORUM 2000. Montreal, Canada. May 16-19, 2000, pp 180-199.
- [Ruiz et al.2000b] Ruiz, O. Neugebauer, P., Topologically Consistent Partial Surface Reconstruction from Range Pictures. Computer Graphics and Imaging (CGIM) conference of IASTED (Intl. Assoc. of Science and Technology for Development). Las Vegas, USA. Nov. 19-23, 2000.
- [Shannon. 1949] Shannon, C., Communication in Presence of Noise. IRE 37, 10-21.
- [Shinagawa et al. 1991] Shinagawa, Y., Kergosien, Y., Kunii, T., Surface coding based on Morse Theory. IEEE Computer Graphics & Applications 11 (5), 66-78.
- [Turk et al.94] Turk, G., Levoy, M., Zipped Polygon Meshed from Range Images. Proceedings SIGGRAPH-94, 1994, pp 311-318.
- [Varady.97] Varady, T., Reverse Engineering of Geometric Models – An Introduction. Computer Aided Design, Vol 29, No 4, 1997, pp 255-268.